

Air Equalizer

Manual

ENG/June 2021

TUAIREQMANEN

 **TULDERHOF**
ventilation & welfare
Looyenbeemd 10
5652 BH Eindhoven
The Netherlands

Read the instructions prior to performing any task!

Original document

Tulderhof Ventilation BV
T +31 (0)40 400 63 13
T +32 (0)14 65 86 91
F +32 (0)14 65 99 60
E sales@tulderhof.com
W www.tulderhof.com

Table of contents

1	General	4
	1.1 Introduction.....	4
2	Safety	6
	2.1 Introduction to Safety.....	6
	2.2 Description of the Signal Words.....	6
	2.3 Description of the Safety Symbols.....	7
	2.4 Personnel Qualification.....	7
	2.5 Safety Notes for the Installation / Decommissioning....	8
	2.6 Safety Notes for the Operation.....	9
	2.7 End of Life (WEEE).....	10
3	Transport and Storage	11
4	Installation	12
	4.1 Technical Specifications.....	12
	4.2 Preparing the Air Equalizer Mounting.....	14
	4.3 Mounting the Air Equalizer in the Roof.....	17
	4.4 Mounting the Optional Chimney Components.....	20
	4.5 Wiring Diagram.....	34
	4.6 Initial Setup.....	36
5	Maintenance	38
	Appendix	39
	A Product Information.....	40

1 General

1.1 Introduction

Product Overview

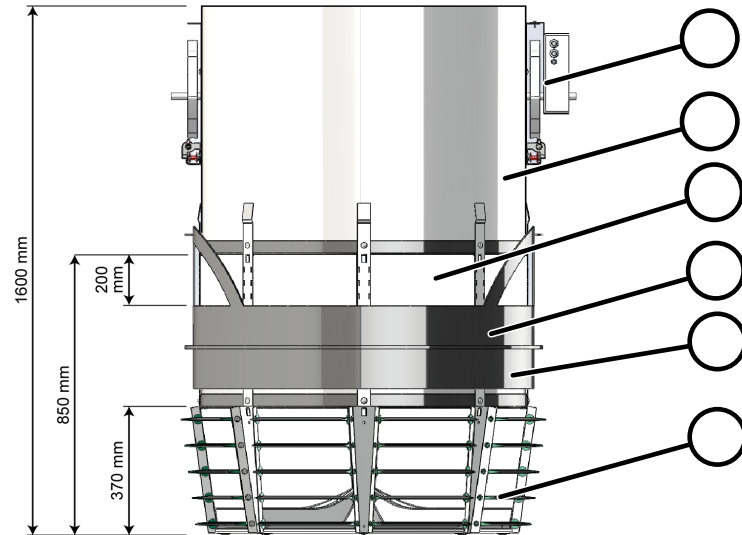

) L J & R P S R Q H Q W V R I W K H \$ L U (T X D O L J H U

- p Belimo actuator for damper and bypass
- q Inlet chimney with damper
- r Bypass
- s Bypass shutter
- t Fan
- u Vanes

General

The Air Equalizer is an inlet chimney for:

- ” houses with equal pressure,
- ” houses with negative pressure, and
- ” monoblock houses.

The Air Equalizer can take in fresh air and mix fresh air with barn air. The adjustable vanes can guide the incoming airflow in any direction.

Bypass

The Air Equalizer has a bypass that can mix warm air from the barn with cold, fresh air. The height of the Air Equalizer will not change.

Types of control:

- ” A ring that moves up and down controls the volume of air that flows through the bypass.
- ” A damper adjusts the volume of fresh air.
- ” A computer-controlled Belimo actuator controls the bypass and the damper simultaneously.

Vanes

The Air Equalizer can spread the incoming/mixed air through the entire house (360 °). The adjustable vanes can guide the air in 8 horizontal directions/zones. Per zone, you can adjust the airflow vertically, or even block it fully.

Belimo Actuator

A Belimo actuator (0-10 V) controls the bypass and the damper. When the bypass is open, the damper is closed, and the other way around.

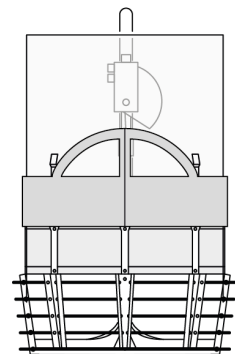
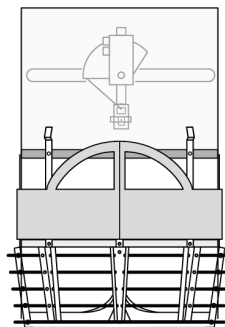

)LJ %\SDVV SRVLWLRQV OHIW RSHQ ULJ

2 Safety

2.1 Introduction to Safety

- ” This manual contains the information required to install, operate and maintain this product. Read the information and instructions thoroughly before use.
- ” This product is covered by the warranty and liability regulations laid down in documents including the manufacturer's general terms of sale governing the contract concluded for the delivery of this product.

2.2 Description of the Signal Words

This document has safety-related and other important messages. Signal words and safety symbols describe the types of messages.



DANGER!

Indicates a hazardous situation which, if not avoided, will cause death or serious injury.

The safety symbol shows the type of hazard.



WARNING!

Indicates a hazardous situation which, if not avoided, could cause death or serious injury.

The safety symbol shows the type of hazard.



CAUTION!

Indicates a hazardous situation which, if not avoided, could cause minor or moderate injury.

The safety symbol shows the type of hazard.



NOTICE!

Indicates a hazardous situation which, if not avoided, could cause machine, property or product damage.



Indicates more information, suggestions and recommendations.

2.3 Description of the Safety Symbols



WARNING!
General warning.



WARNING!
Risk of injury from electrical voltage.



Eye Protection
Wear eye protection.



Protective Clothing
Wear protective clothing.



Protective Gloves
Wear protective gloves.



Safety Footwear
Wear safety footwear.

2.4 Personnel Qualification

Installer

Installers are all persons that do these actions with regard to the product:

- ” Installation
- ” Maintenance
- ” Troubleshooting

Installers must be qualified electricians. Each installer must have a profound professional experience and knowledge of:

- ” Electronic and electrical installations.
- ” The national and international regulations and legislation on electronic and electrical installations.
- ” Safety regulations.
- ” Possible dangers during the installation, maintenance and troubleshooting.
- ” Commissioning of the product.

Preferably, all installers have passed the product training of the manufacturer.

User

Users are all persons that operate this product. Users are only permitted to operate this product when:

- ” they have read and understood the instructions in this manual.
- ” they know the consequences of changes to settings.
- ” they know the possible dangers of incorrect use of this product.
- ” they know the possible dangers of the connected systems, especially systems that start automatically.
- ” during normal operation, they keep the cover of the housing closed, unless the manufacturer or this manual gives other instructions.

2.5 Safety Notes for the Installation / Decommissioning

Personnel: ” Installer

Protective equipment: ” Eye Protection
 ” Protective Clothing
 ” Protective Gloves
 ” Safety Footwear

- ” The installation and decommissioning are an integral part of the product. Only professional installers are permitted to install and decommission this product.
- ” Install the product according to prevailing standards (BS, ANSI, ISO, DIN, NEN, for example).
- ” Before the installation, refer to the "Technical Specifications" section(s) in this manual.
- ” Secure the installation wiring to the product housing or cabinet to prevent short circuits.
- ” Always disconnect the power supply before you do any work on electrical components.
- ” When there is a risk of injuries, wear the protective equipment described above when you install, maintain and clean the product.

2.6 Safety Notes for the Operation

- Personnel: " User
- Protective equipment: " Eye Protection
 " Protective Clothing
 " Protective Gloves
 " Safety Footwear
- " Only persons who have read and understood the instructions in this manual are permitted to operate this product.
- " Persons who operate or adjust this product must know the possible dangers of the connected systems.
- " Only use this product for its intended use. Any other use than this is considered as inappropriate use.
- " This product can be an integral part of a system with moving parts that start any time automatically. These moving parts could cause injury to persons. The presence of persons near the moving parts is not permitted. At least once a day, do a check on the correct operation of the guards or protective devices.
- " When there is a risk of injuries, wear the protective equipment described above when you operate, maintain and clean the product.

2.7 End of Life (WEEE)

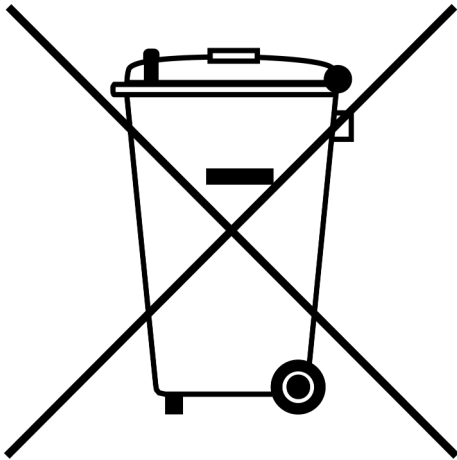

The crossed-out wheeled bin indicates a product that, at the end of its life cycle, must be collected separately (Directive 2012/19/EU on waste electrical and electronic equipment - WEEE). Separate collection is a precondition to ensure specific treatment and recycling of WEEE to get the chosen level of protection of human health and the environment in the Union. The black bar below the crossed-out wheeled bin indicates that the product was put on the market on or after August 13, 2005.

The European Union has systems in place for the separate collection of waste electrical and electronic products and batteries. Thus, return waste products, batteries and accumulators to the appropriate local authorities, or a local collection point/recycler. When you do not dispose of the product correctly, you may be fined.



)LJ &URVVHG RXW ZKHHOHG ELQ

3 Transport and Storage

- " Examine the product for transport damage.
- " Examine if the product is what you ordered.
In case of incorrect delivery or damage, please contact your supplier immediately.
- " Store the product in a dry and clean environment.
- " Store the product in such a way that it is protected from:
 - humidity,
 - dust,
 - dirt,
 - direct sunlight,
 - aggressive, chemical substances, and
 - mechanical vibrations.

4 Installation

4.1 Technical Specifications

Air Equalizer - General	
Height	1600 mm
Outside diameter	” Air Equalizer: max. 1020 mm ” Chimney: 980 mm
Surface area	2200 cm ²
Weight	≈ 63 kg
Material	Foamed PU (30 mm) with polyester
Capacity > 3 D @	19,500 m ³ /h
Pull force	7.5 kg/m
Stroke	250 mm
Thermal conductivity	0.022 W/mK

Damper	
Rated voltage	AC/DC 24 V (Canada = AC 230V)
Rated frequency	50/60 Hz
Rated voltage range	AC/DC 19.2 ... 28.8 V (Canada = AC 85...264 V)
Power consumption (operation)	2 W (Canada = 3.5 W)
Power consumption (standby)	0.4 W (Canada = 1 W)
Connection	Cable 1 m, 4 x 0.75 mm ²
Motor torque	Min. 20 Nm
Operating range	DC 2 ... 10 V

Fan	
Rated voltage U_N	3~ 230/400 V (Δ/Y) $\pm 10\%$
Rated frequency f_N	50/60 Hz
Rated input power P_1	1.30 kW

Fan	
Rated current I_N	3.30 / 1.90 A (50 Hz)
	4.20 / 2.40 A (60 Hz)
Rated speed n_N	930 min ⁻¹
Starting current I_A	11.00 / 6.00 A

4.2 Preparing the Air Equalizer Mounting

Making a Roof Template

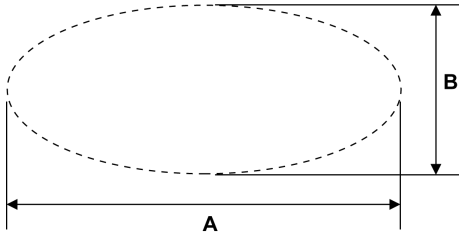

- A Depends on the roof pitch. Use the formula " $A = B / C$ " to calculate the roof pitch μ & IDFWRU IRU URRI SLWF RQ SD J for "C".
- B Outside diameter of the chimney > P.P @

i It is recommended to use a firm cardboard for the template. A hole in a slanting roof must have an elliptical shape.

7DE & IDFWRU IRU URRI SLWFKHV

\hat{o}	C	\hat{o}	C	\hat{o}	C	\hat{o}	C
10 r	0.9848	17 r	0.9563	24 r	0.9135	31 r	0.8571
11 r	0.9816	18 r	0.9511	25 r	0.9063	32 r	0.8480
12 r	0.9781	19 r	0.9455	26 r	0.8988	33 r	0.8386
13 r	0.9744	20 r	0.9397	27 r	0.8910	34 r	0.8289
14 r	0.9703	21 r	0.9336	28 r	0.8829	35 r	0.8189
15 r	0.9659	22 r	0.9272	29 r	0.8746	36 r	0.8087
16 r	0.9613	23 r	0.9205	30 r	0.8660	37 r	0.7982

Drawing and Cutting the Roof Template

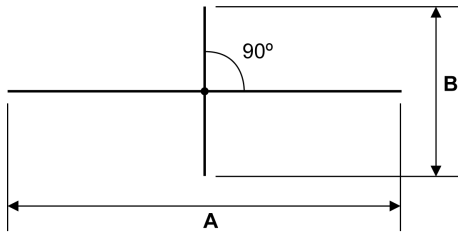

1. Draw the lines A and B on the cardboard. The intersection is in the middle of A and B.

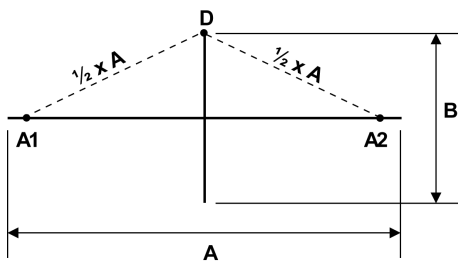

2. Draw two lines with a length of $\frac{1}{2} \times A$ from point D to line A. Put marks on the cardboard at A1 and A2.

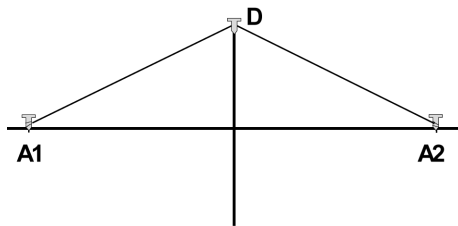

3. Put a nail at the points A1, A2, and D. Attach a string to A1. Guide the string tight but without stretch via D to A2. Attach the string to A2.

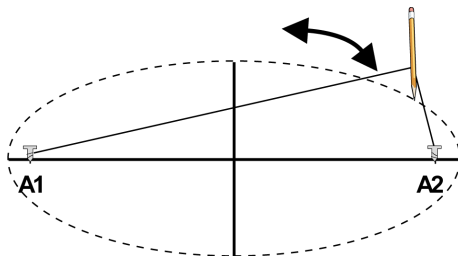

4. Remove the nail from D.

5. Put a pencil in the string. Keep the pencil tight and vertically to the string, and draw the ellipse on the cardboard.

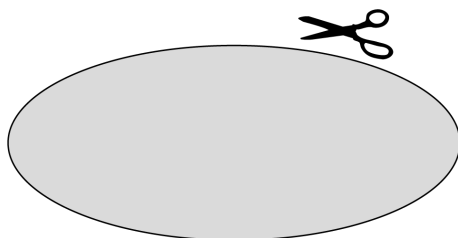

6. Cut the template along the line.

Position of the Chimneys in the Roof

You can mount the chimneys as follows:

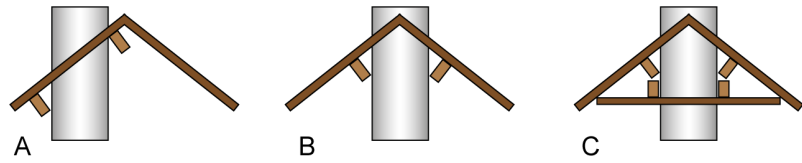

) LJ 3 R V V L E O H F K L P Q H \ S R V L W L R Q V L Q W K H U

A wooden framework is necessary to get a solid suspension. This framework must have inner dimensions that agree with the outside diameter of the chimney.

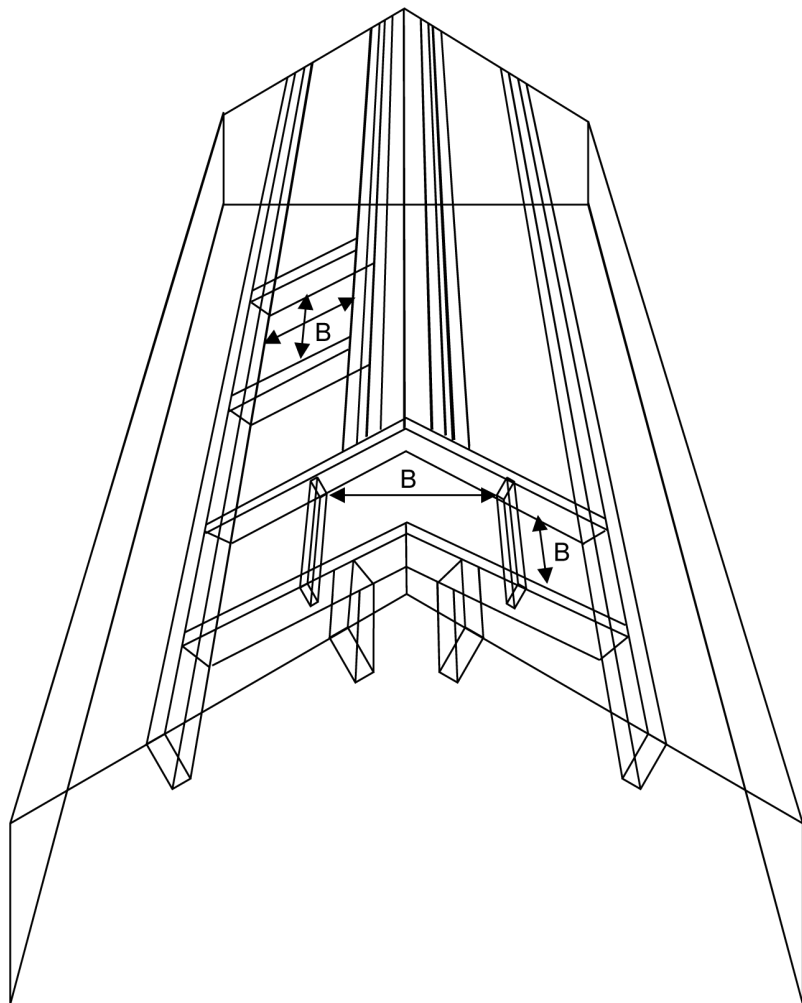

) LJ 3 R V V L E O H F K L P Q H \ O R F D W L R Q V L Q W K H U

% = Outside diameter of the chimney > P P @

4.3 Mounting the Air Equalizer in the Roof

Making the Hole in the Roof



CAUTION!

Before you cut the hole through the roof, first do a check if the location of the framework is suitable.



NOTICE!

Always keep the saw and the drill bit perpendicular to the roof.

1. Put the template from the inside against the inner roof plate or isolation construction ^a μ 0 D N L Q J D 5 R R I 7 H P S O D W R Q S D J H



Fold the template when you mount the chimney in a ridge.

2. Draw the hole.
3. Saw the hole from the inside through the inner roof plate or isolation construction.
4. Mark the four outer positions (top, bottom, left, right) of the template on the inside of the outer roof.
5. Drill four holes in the outer roof.
6. Put the template from the outside against the outer roof.
Make sure that the template is between the holes you have drilled.
7. Draw the hole.
8. Cut the hole from the outside through the roof.



- If necessary, make a framework ^a μ 0 D N L Q J D) U D P H Z R U N 2 S W L R C R Q S D J H
- When a framework is not necessary, you can mount the Air Equalizer directly ^a μ 0 R X Q W L Q J W K H & K L P Q H \ | R Q S

Making a Framework (Optional)

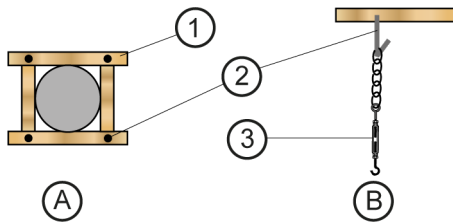

⌘ Bottom view
⌘ Side view

1. ➤ If necessary, make a framework.

For situation C ^a μ 3 R V L W L R Q R I W K H & K L P Q H \ V L Q W R Q S D J H no frameworks are necessary:

- ” 1x under the roof, and
- ” 1x above the ceiling.

2. ➤ Mount the suspension hooks q at the framework corners p.
3. ➤ Attach a chain to the suspension hooks q.
4. ➤ Attach the turnbuckles r to the chain with the S-hooks.

Mounting the Chimney

1. ➤ Guide the Air Equalizer from the inside through the roof. If necessary, use a single or double anchoring ring ^a μ 0 R X Q W L Q J W K H 6 L Q J O H 5 L Q J ¶ R Q S D J H

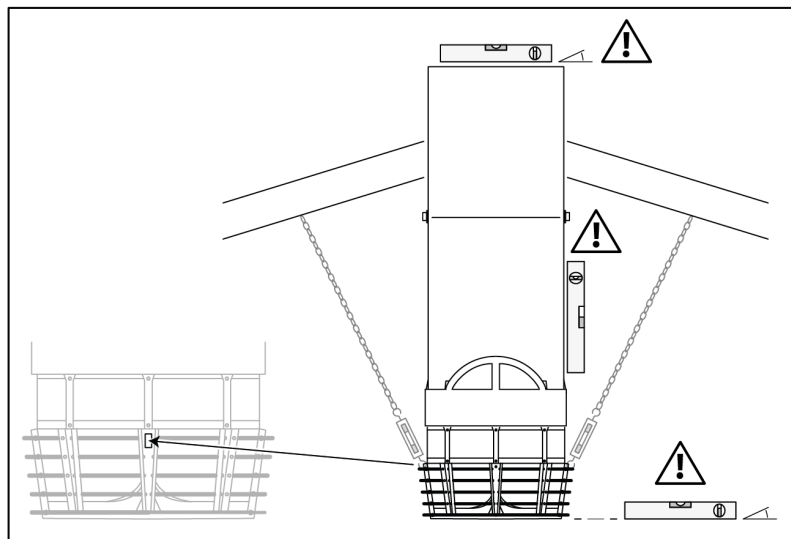

2. ➤ Mount the Air Equalizer to the roof with the suspension cables, hooks and turnbuckles. Make sure that the Air Equalizer is spirit level.
3. ➤ Mount the rain hood with the bird protection ^a μ 0 R X Q W L Q J W K H 5 D L Q + R R G ¶ R a d S D J H μ 0 R X Q W L Q J W K H % L U G 3 U R W L R Q ¶ R Q S D J H
4. ➤ Seal the roof and the Air Equalizer ^a μ 0 R X Q W L Q J W K H 8 Q L Y H 5 R R I L Q J 3 D Q H O ¶ R Q S D J H

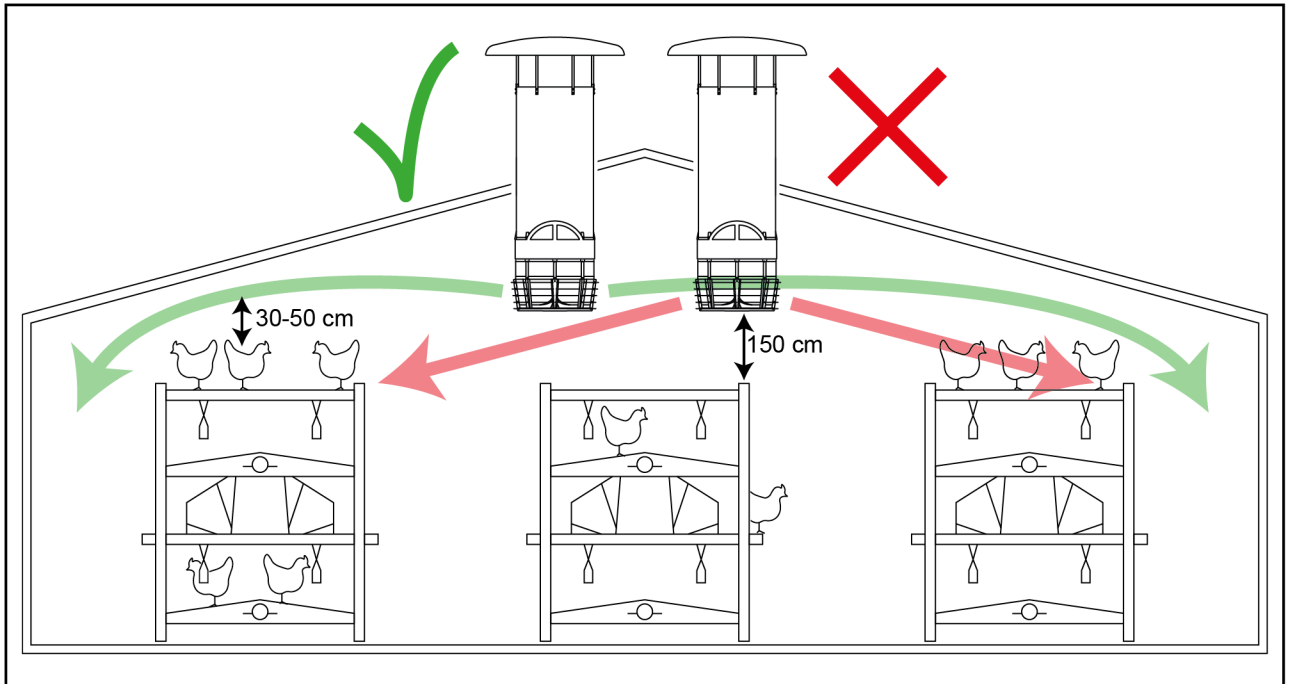

5. ➤ Adjust the vanes to the positions that give the desired airflow.
6. ➤ Connect the power to the fan and damper ^a & K D S W H U
μ: LULQJ 'LDJUDP,¶ RQ SDJH

4.4 Mounting the Optional Chimney Components

Mounting the Segments

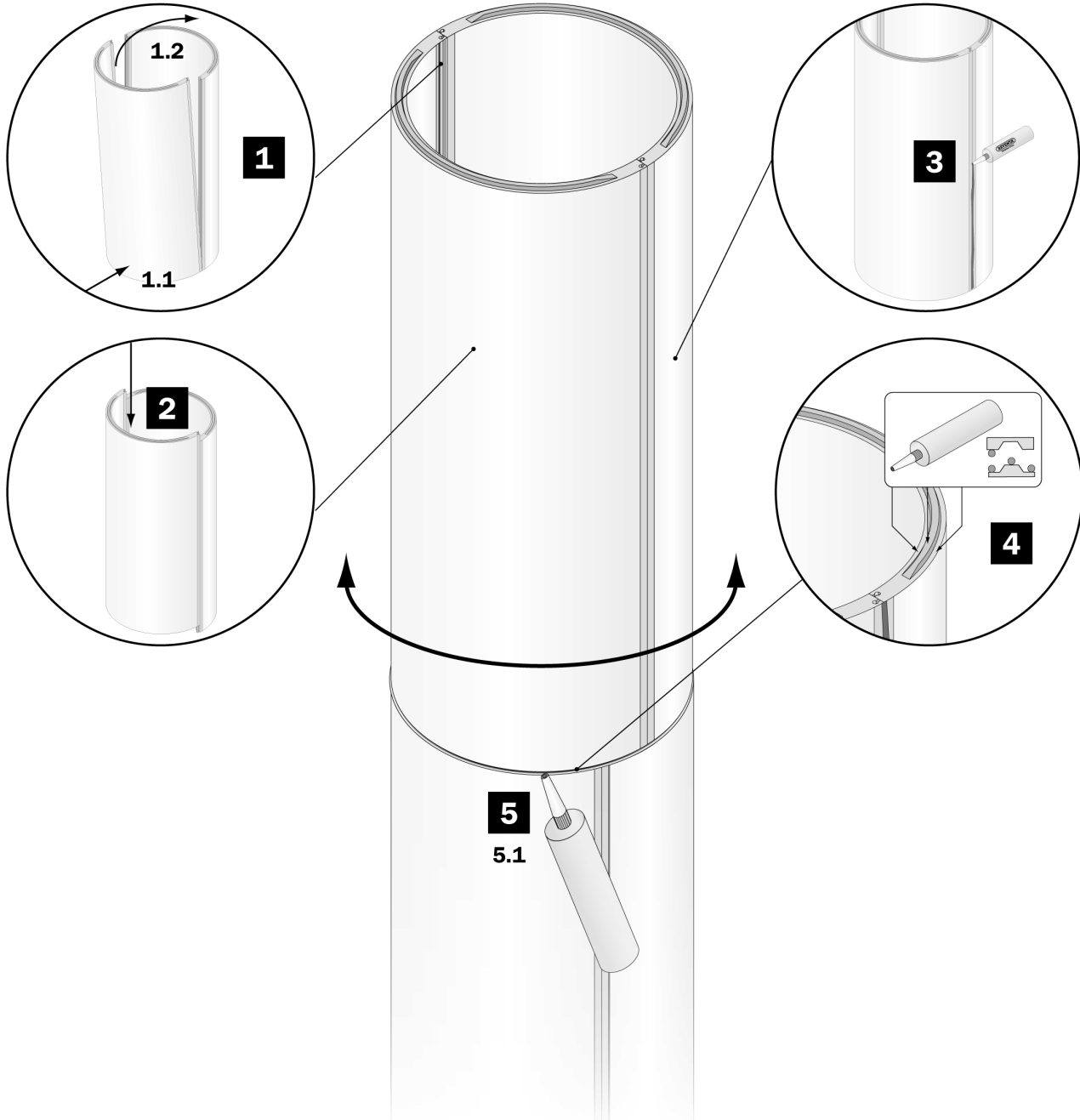

)LJ 0RXQWLQJ WKH VHJPHQWV RI WKH FKLPQH\

Mounting the Clamp

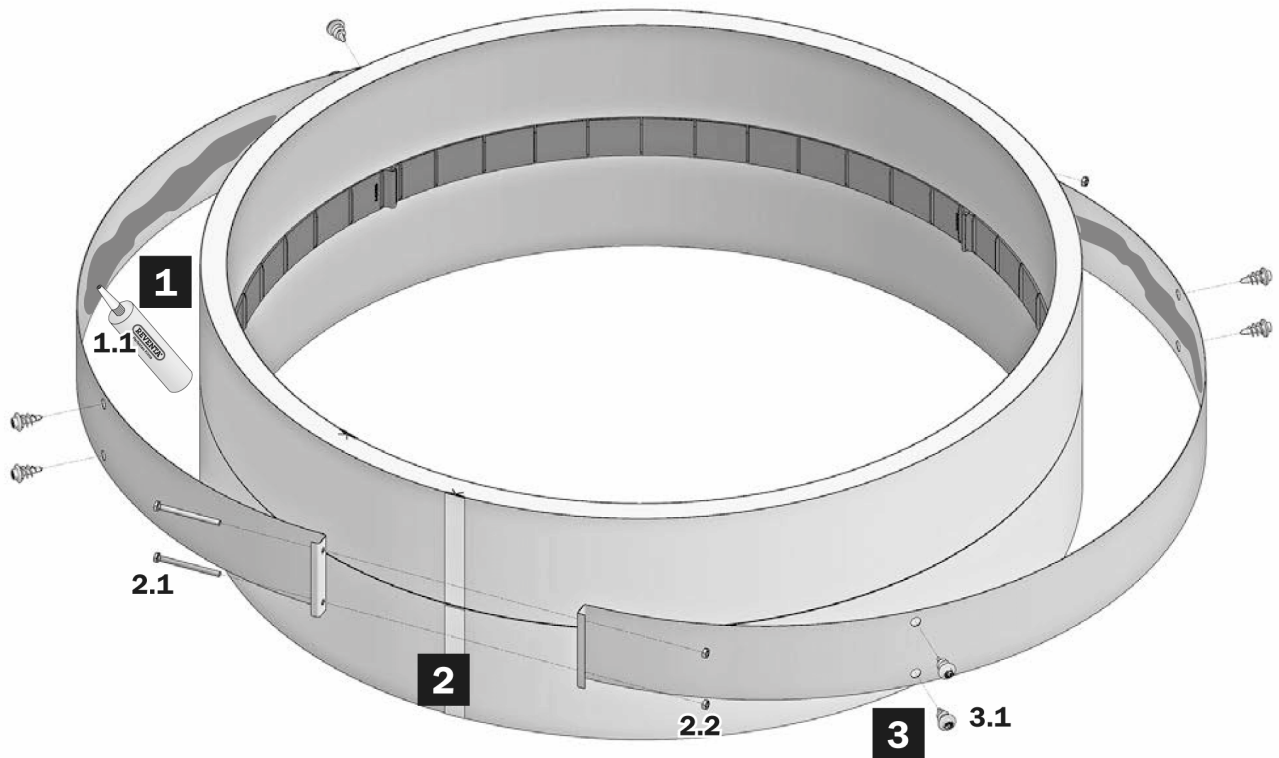

)LJ 0RXQWLQJ WKH FODPS

Mounting the Single Ring

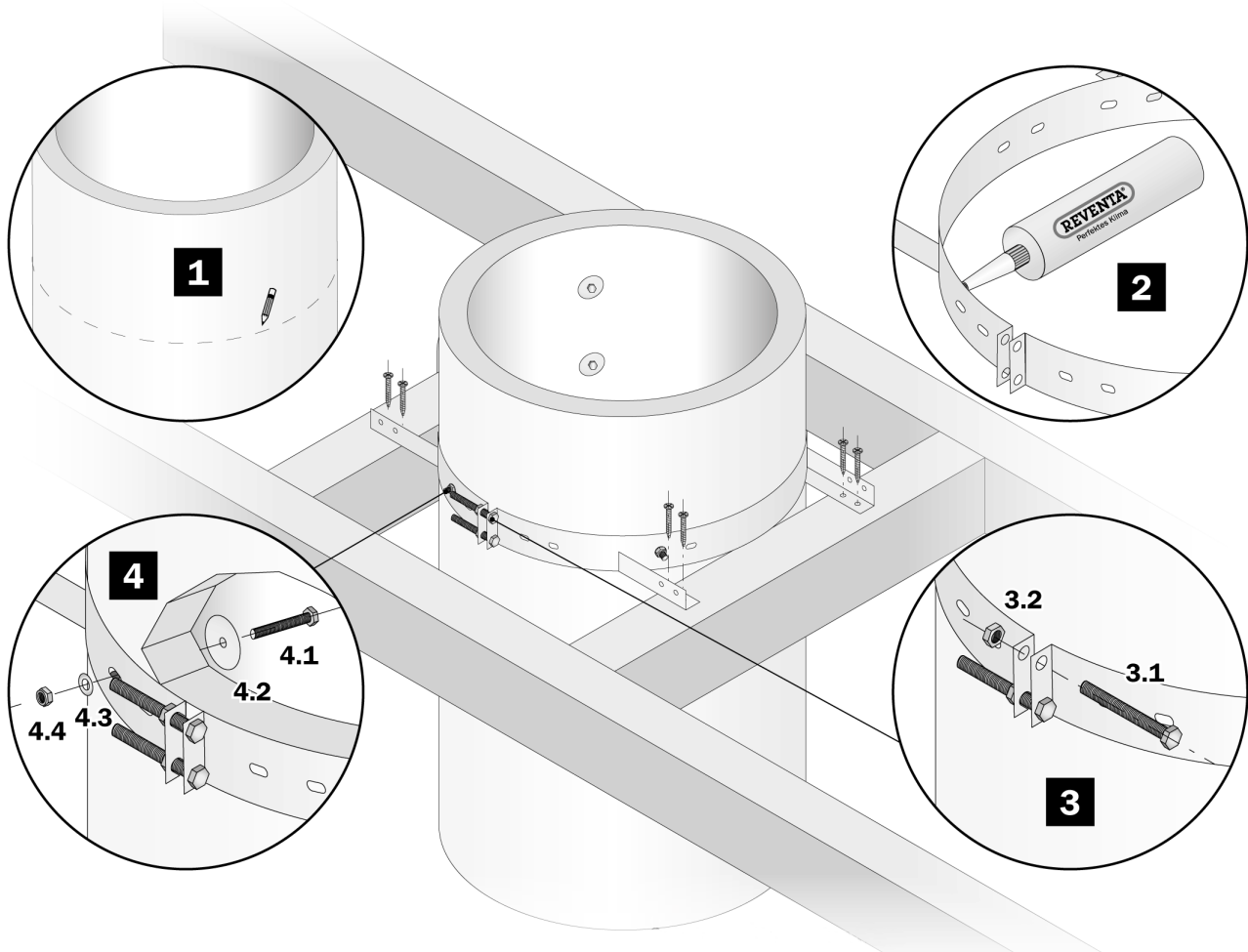

)LJ 0RXQWLQJ WKH VLQJQH ULQJ RI WKH FKLPQH\ DQFKRULQJ

Mounting the Double Ring

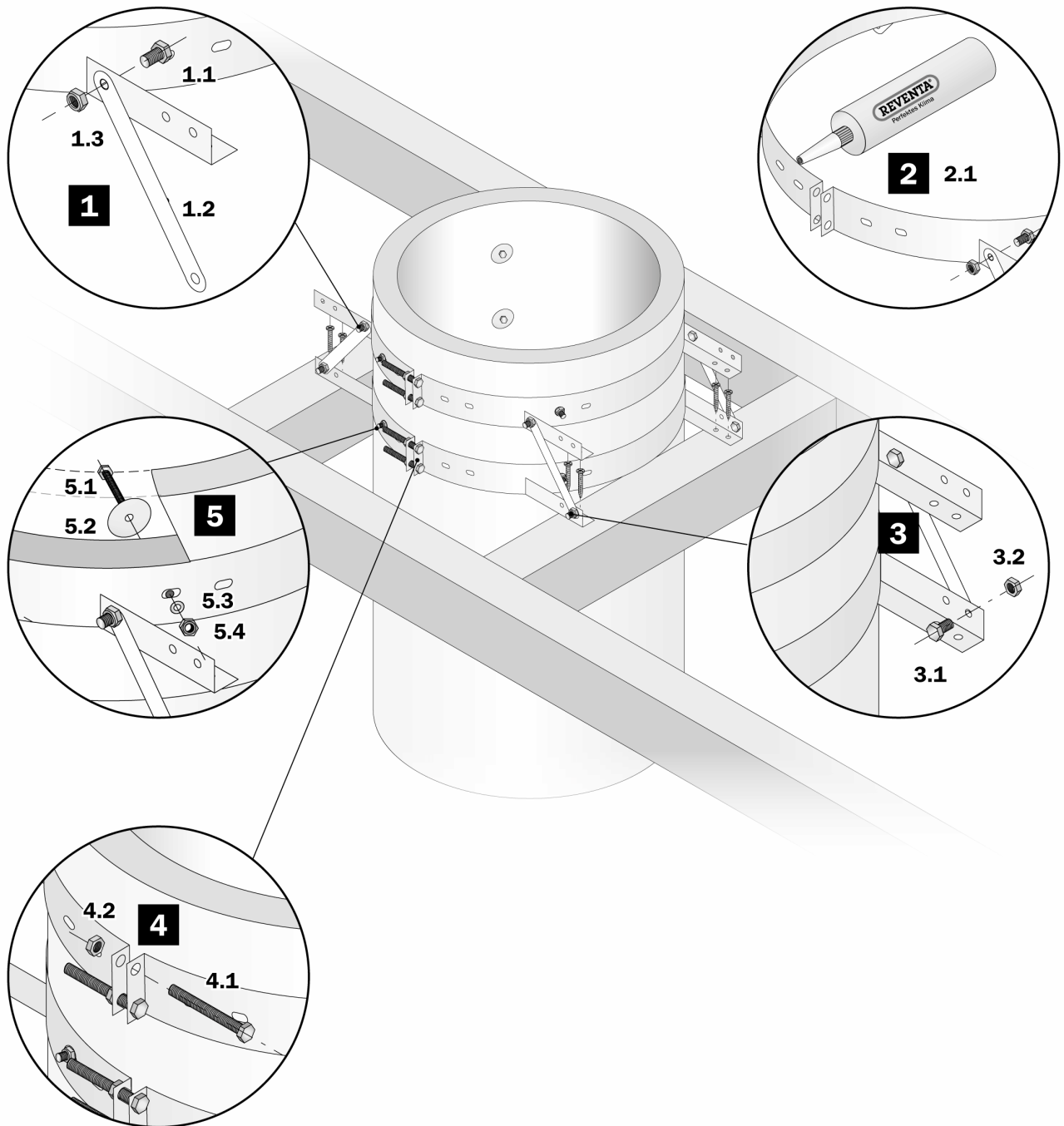

)LJ 0RXQWLQJ WKH GRXE0H ULQJ RI WKH FKLPQH\ DQFKRULQJ

Mounting the Outer Clamp

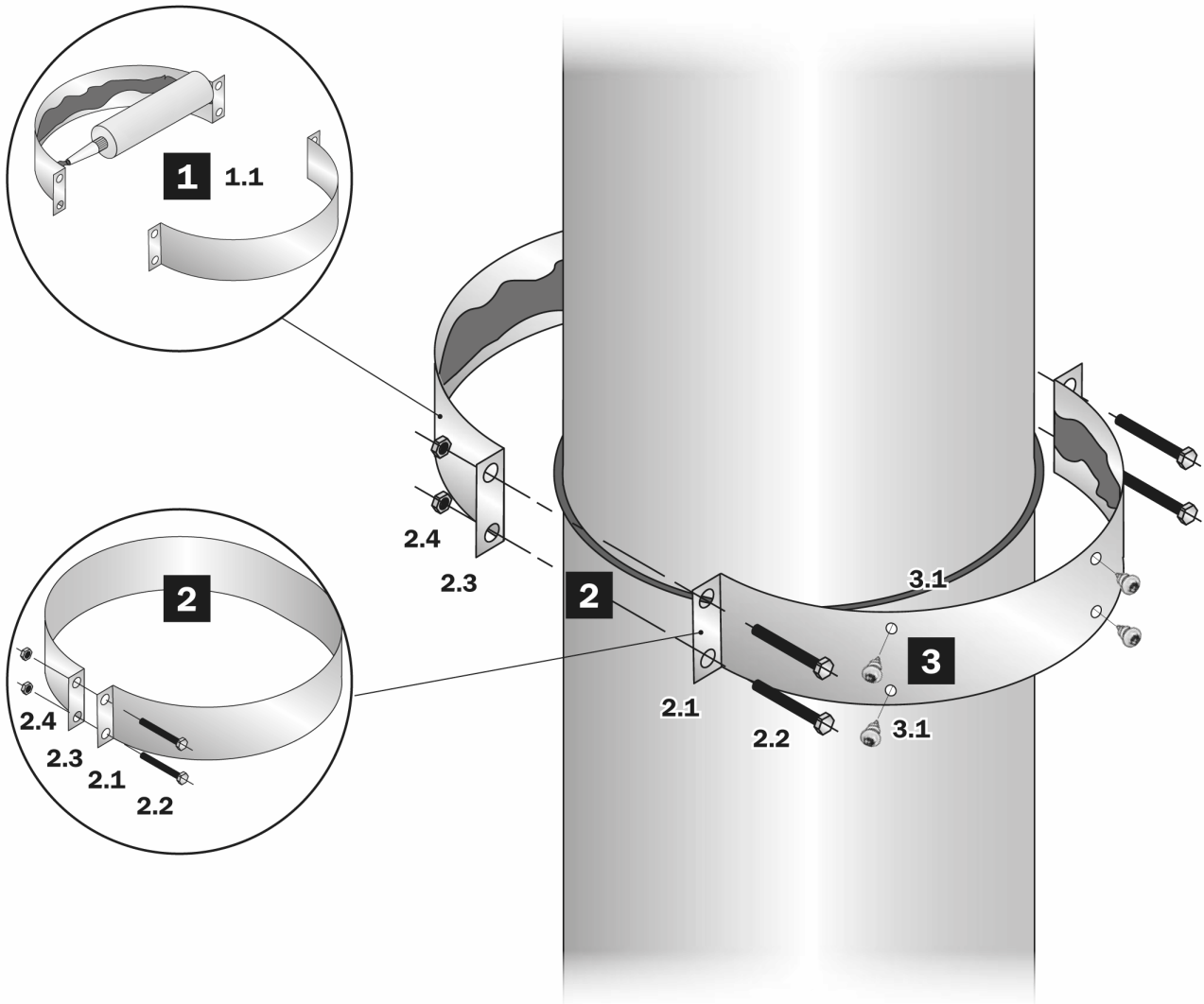

)LJ 0RXQWLQJ WKH RXWHU FODPS

Mounting the Inner Clamp

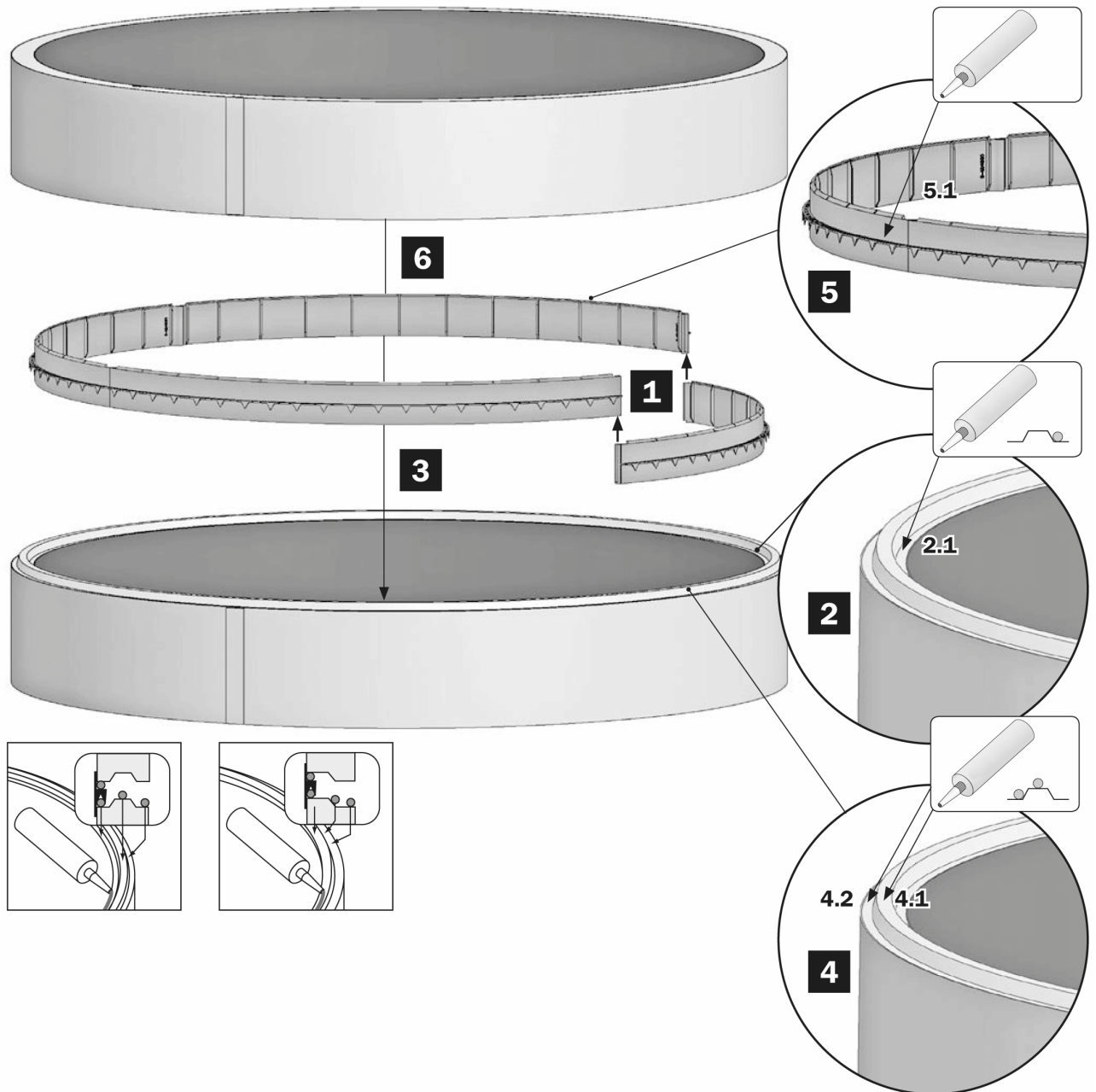

)LJ 0RXQWLQJ WKH LQQHU FODPS

Mounting the Rain Hood

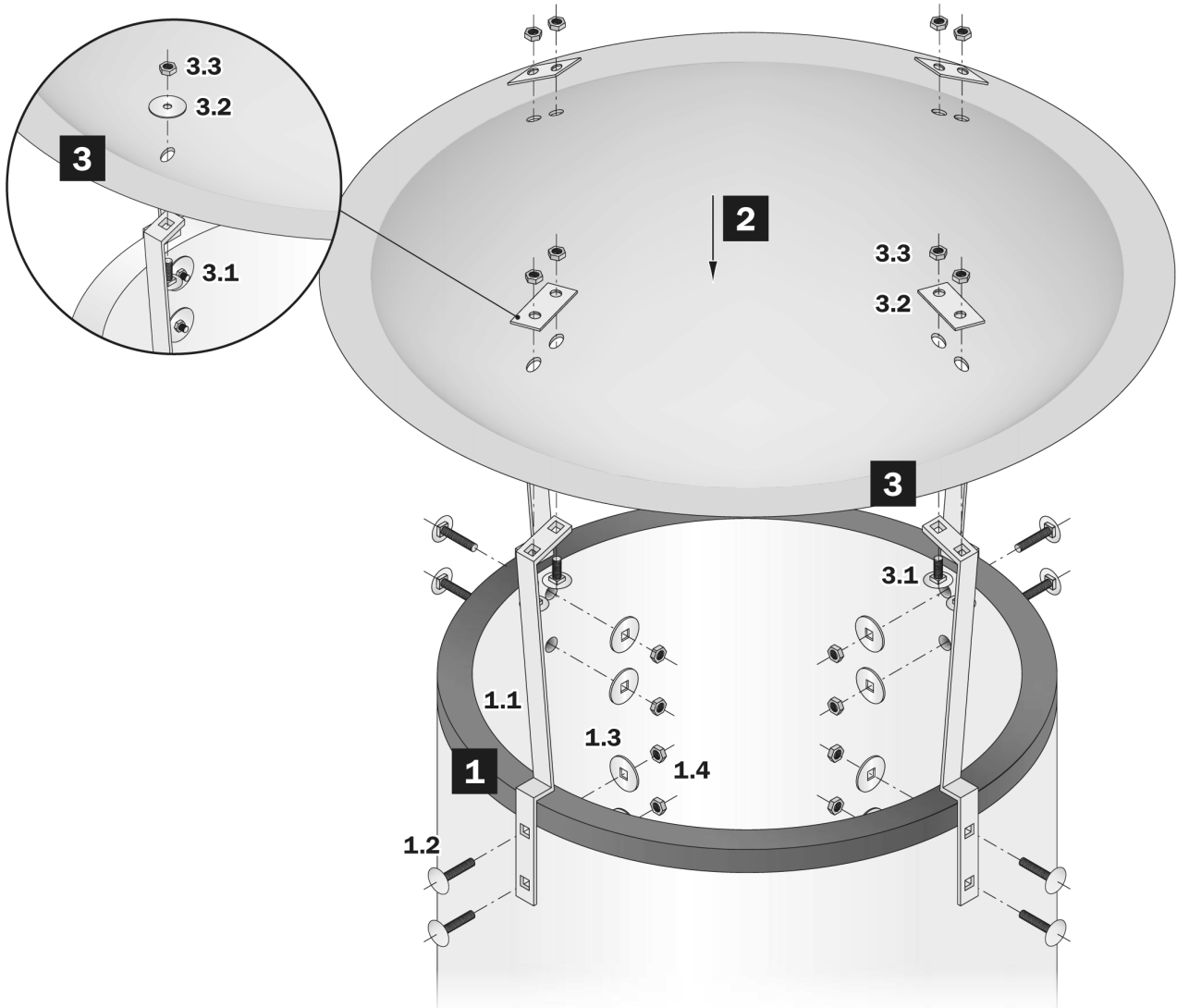

)LJ 0RXQWLQJ WKH UDLQ KRRG

Mounting the Bird Protection

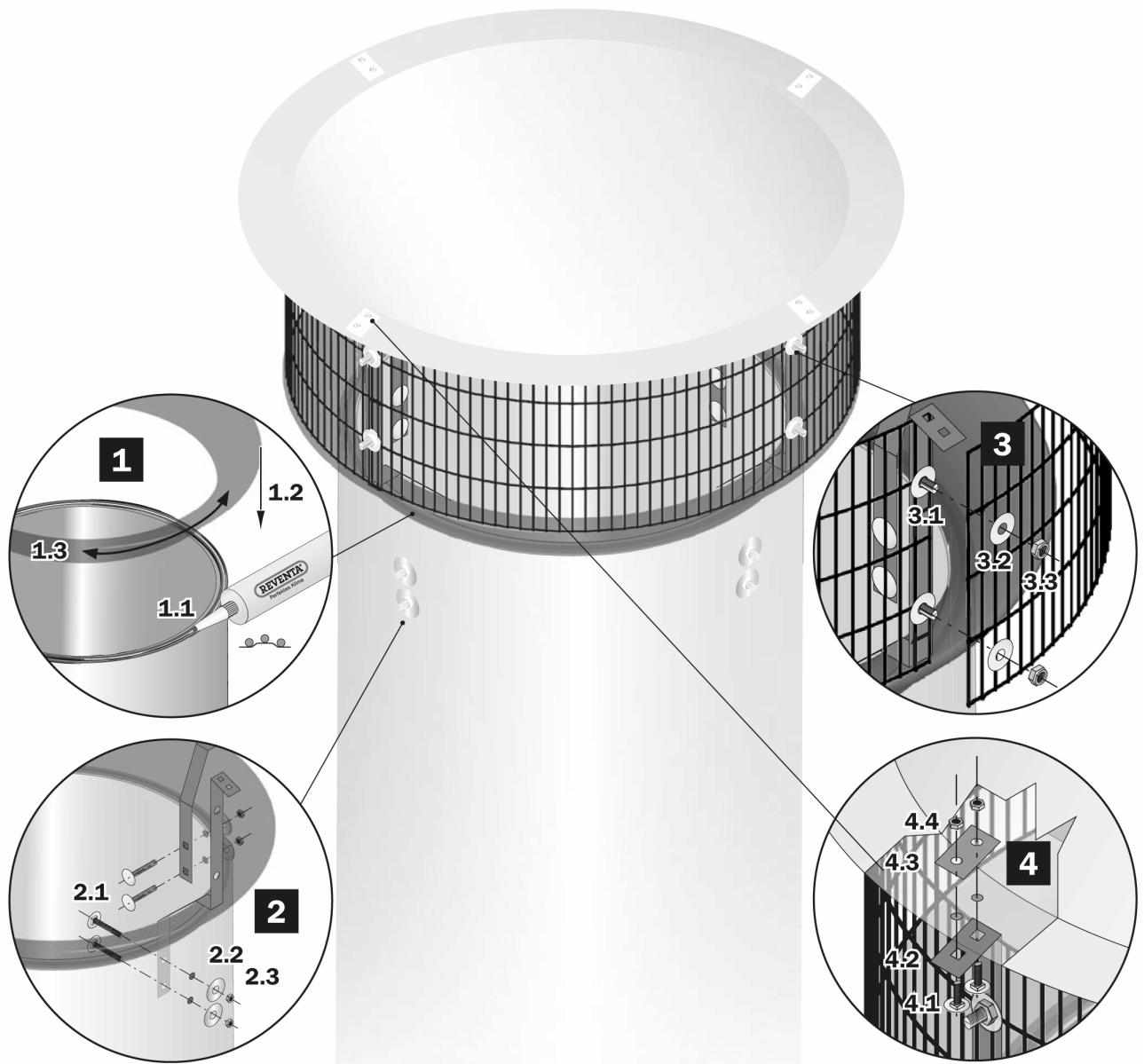

)LJ 0RXQLQJ WKH ELUG SURWHFWLRQ

Mounting the Universal Roofing Panel

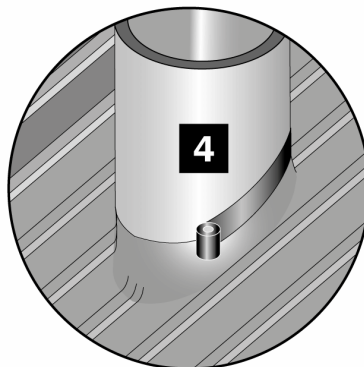
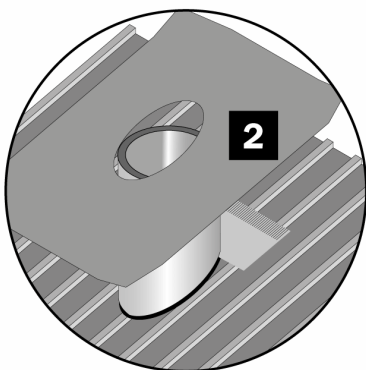
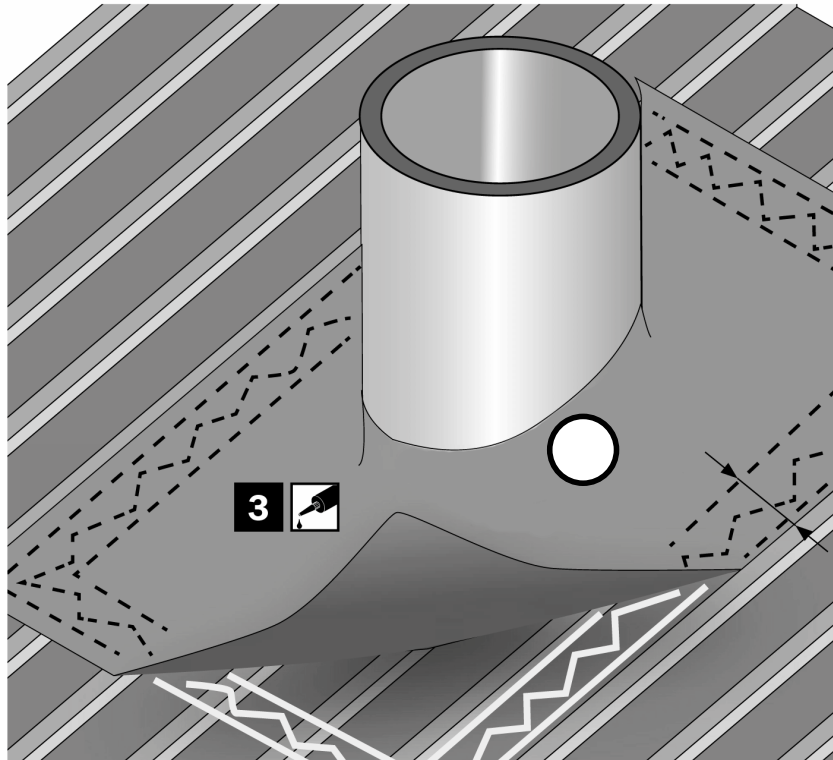
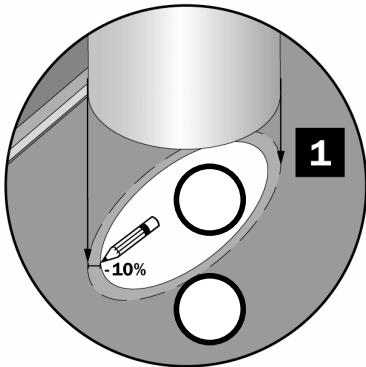
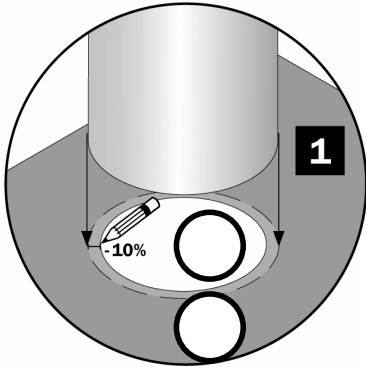

)LJ ORXQWLQJ WKH XQLYHUVDO URRILQJ SDQHO

p Hole size

q Horizontal or low-pitched roof

r High-pitched roof

s The circumferential adhesive surface must have a width of minimum > P P @

Mounting the GITTEX Roofing Panel

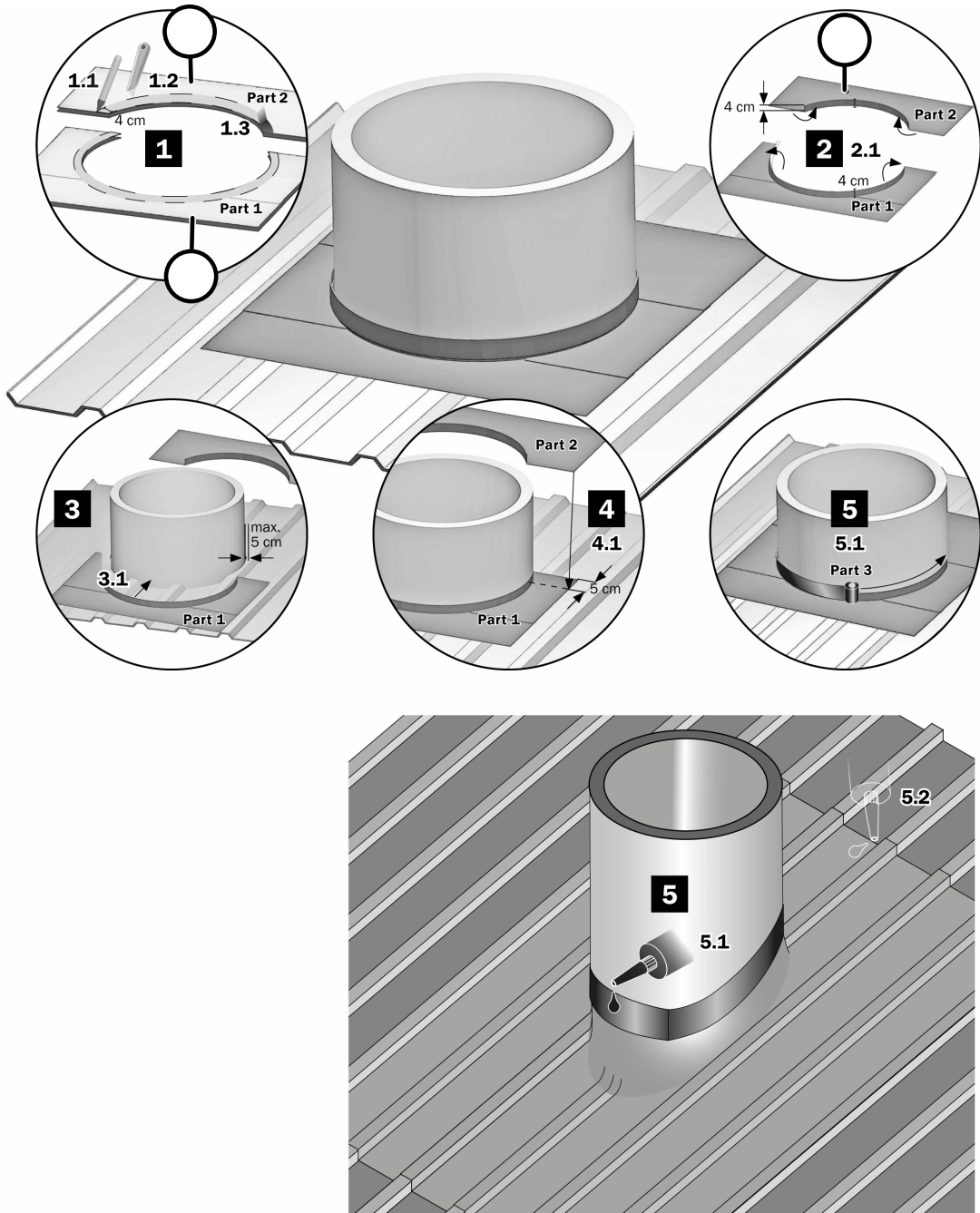

) LJ 0RXQWLQJ WKH *,77(; URRILQJ SDQHO

- p Protection foil
- q GITTEX materials

Mounting the GRP Roofing Panel

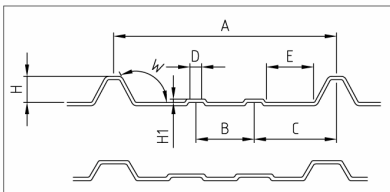
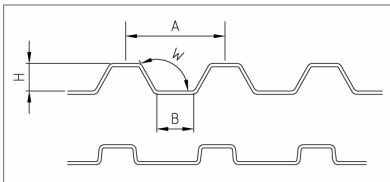
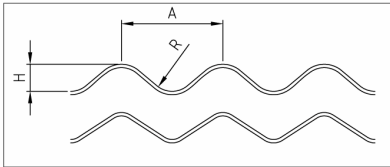

A	
H	
R	
A	
H	
B	
W	
A	
H	
B	
C	
D	
E	
H1	
W	

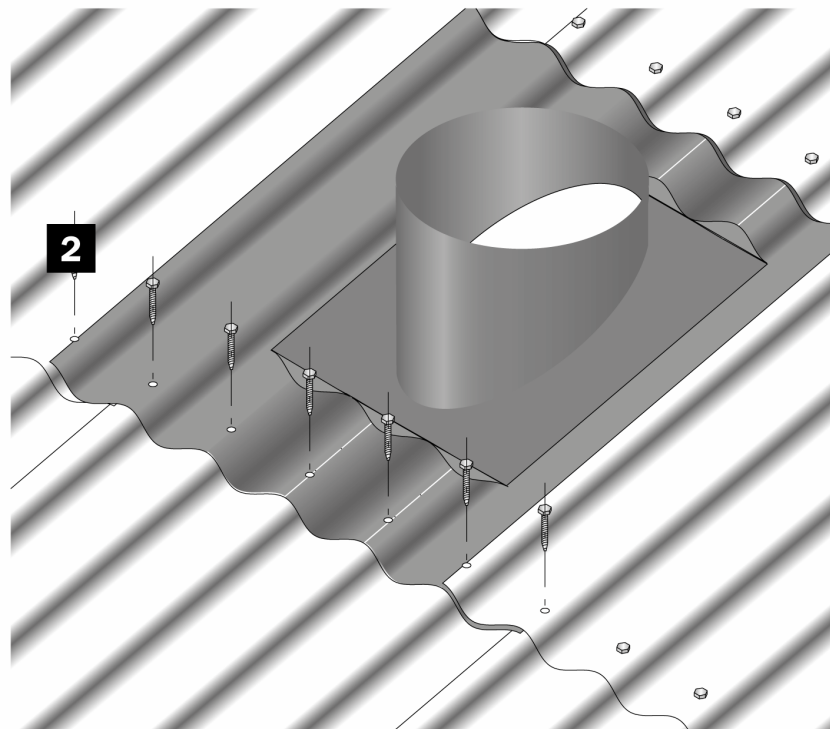
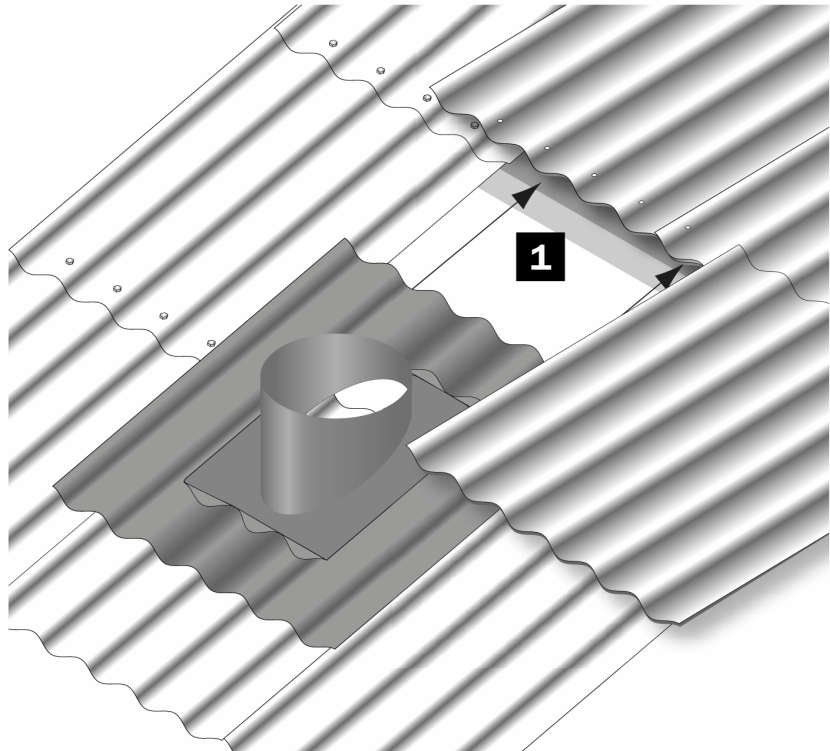

)LJ 0RXQLQJ WKH *53 URRILQJ SDQHO

p Profile / roof pitch:

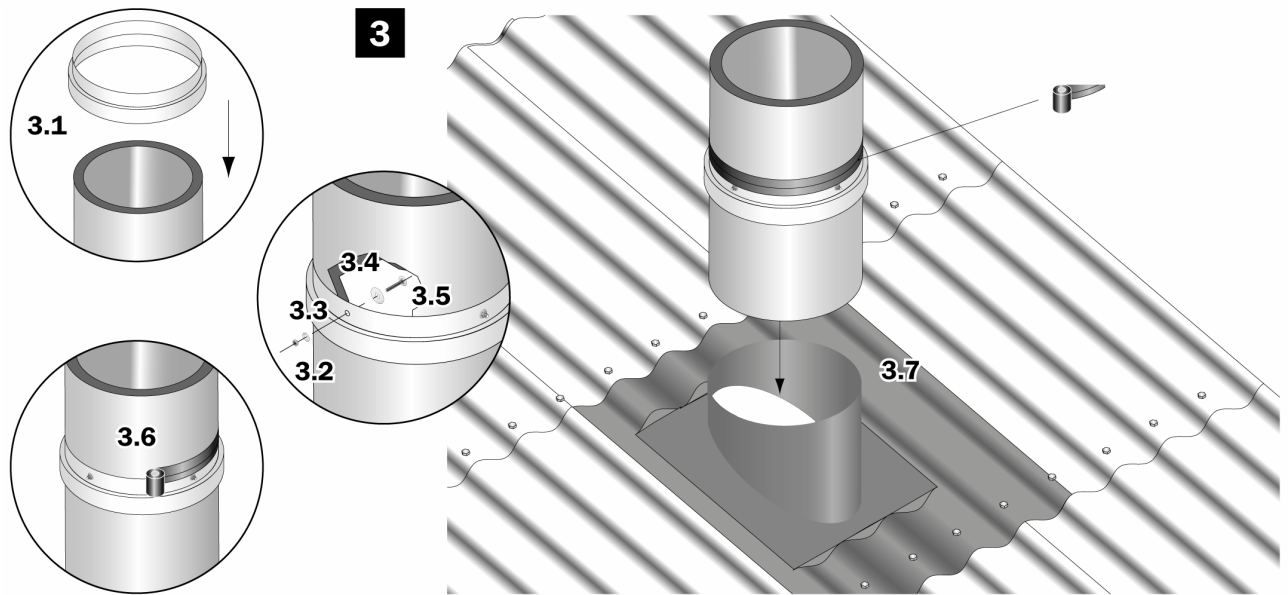

)LJ 0RXQWLQJ WKH *53 URRILQJ SDQHO

Mounting the GFK Roofing Panel

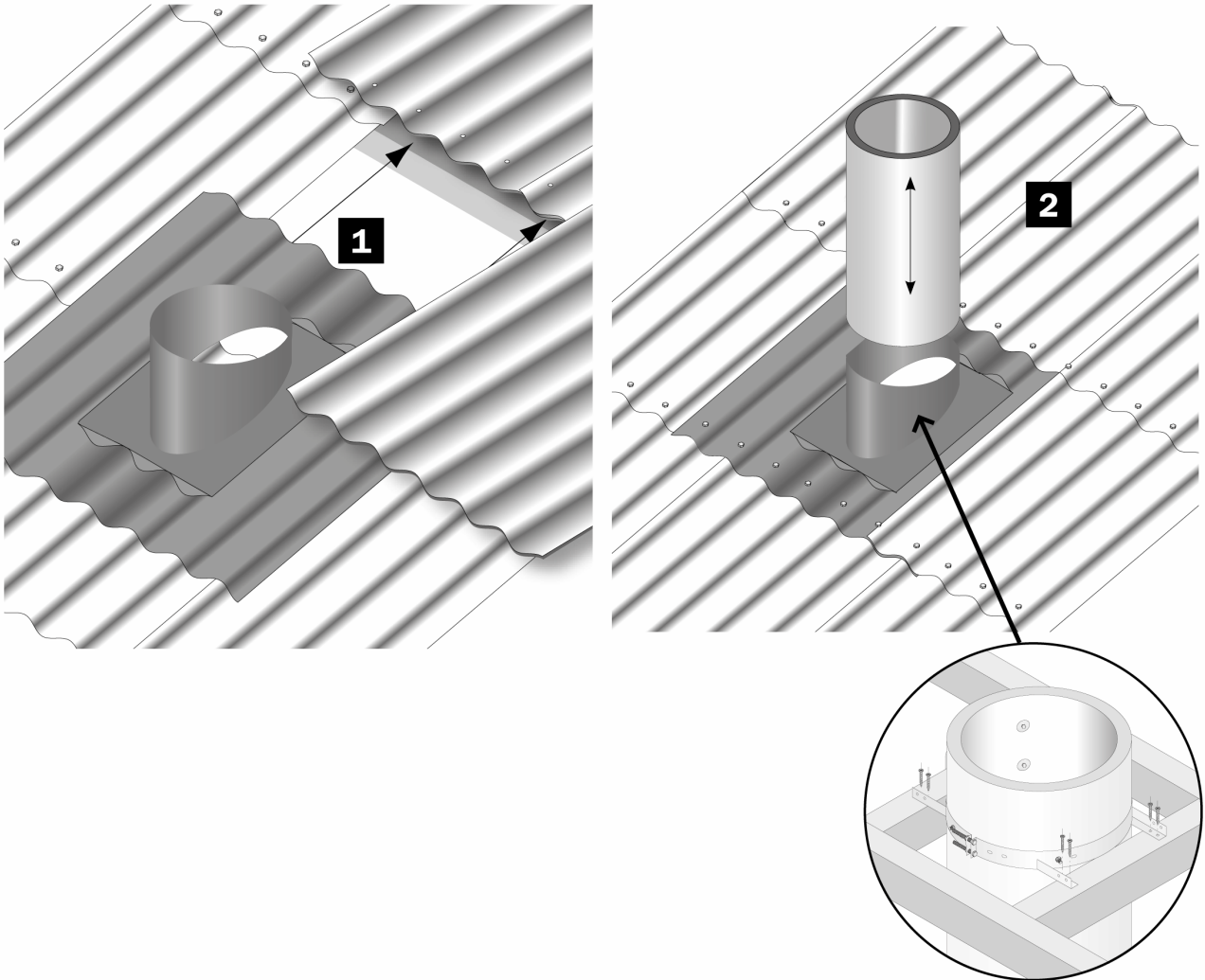

)LJ 0RXQWLQJ WKH *). URRILQJ SDQHO

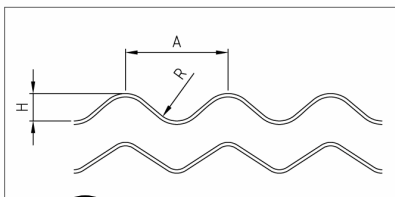
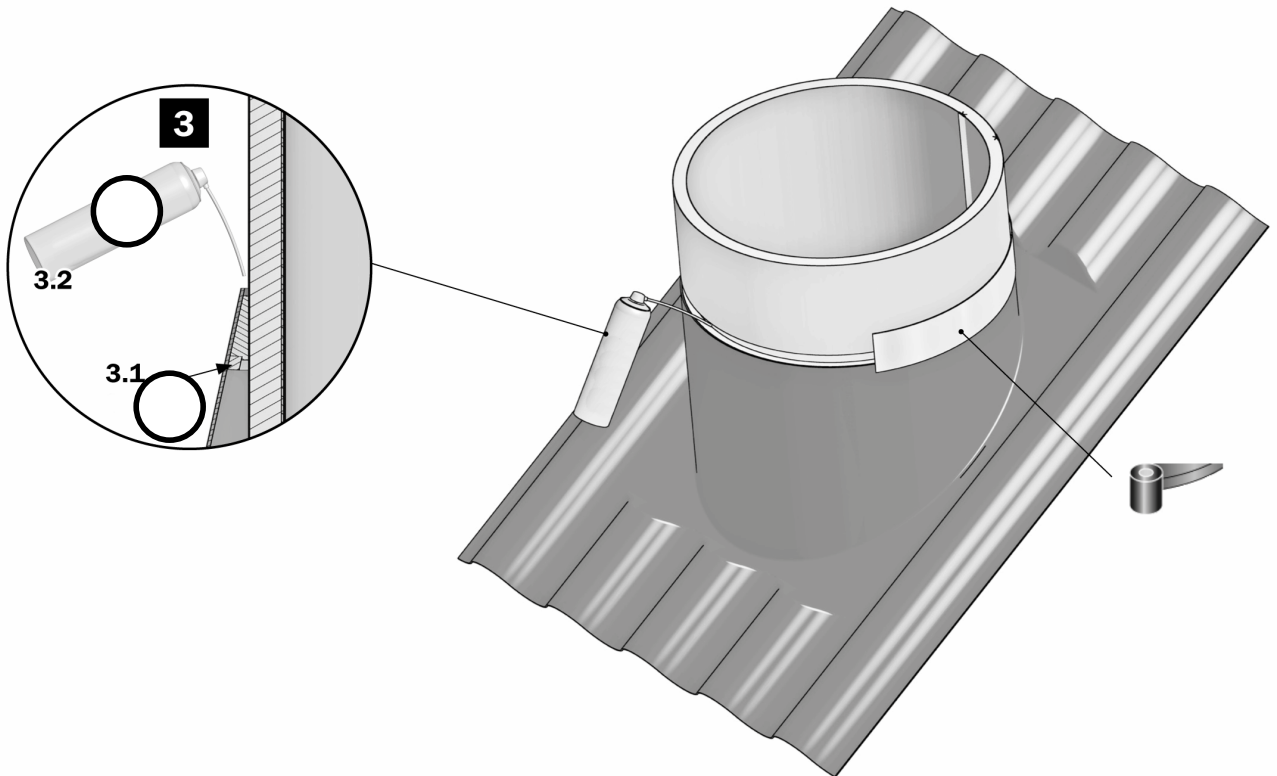

A
H
R

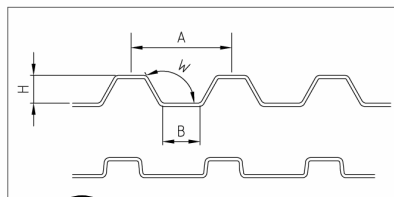

A
H
B
W

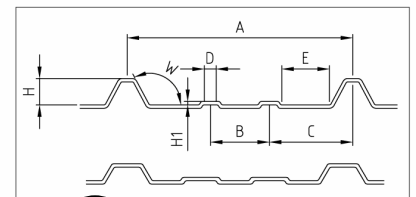

A
H
B
C
D
E
H1
W

) LJ 0RXQWLQJ WKH *). URRILQJ SDQHO

- p PU foam
- q Swelling tape
- r Profile / roof pitch:

4.5 Wiring Diagram



WARNING!

Electric shock can cause serious injury.

Always disconnect the power supply to the system before you do work on the electrical components. When this is not possible, be very careful that you do not touch live parts.

Damper

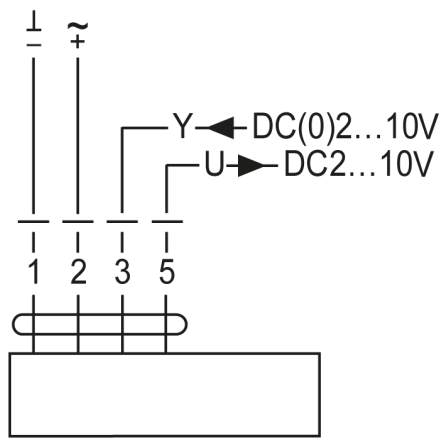

- 1 = BK
- 2 = RD
- 3 = WH
- 5 = OG

)LJ :LULQJ GLDJUDP RI WKH GDP SHU \$ & ' &

AC 230 V, modulating

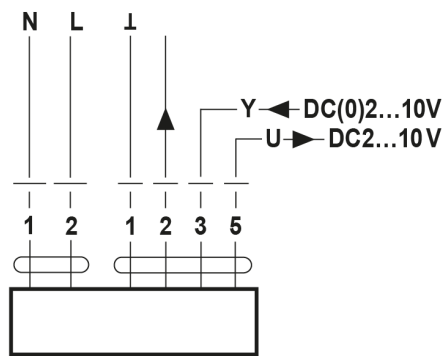

- 1 = BU
- 2 = BN
- 1 = BK
- 2 = RD
- 3 = WH
- 5 = OG

)LJ :LULQJ GLDJUDP RI WKH GDP SHU \$ & 9
&DQDGD

Fan

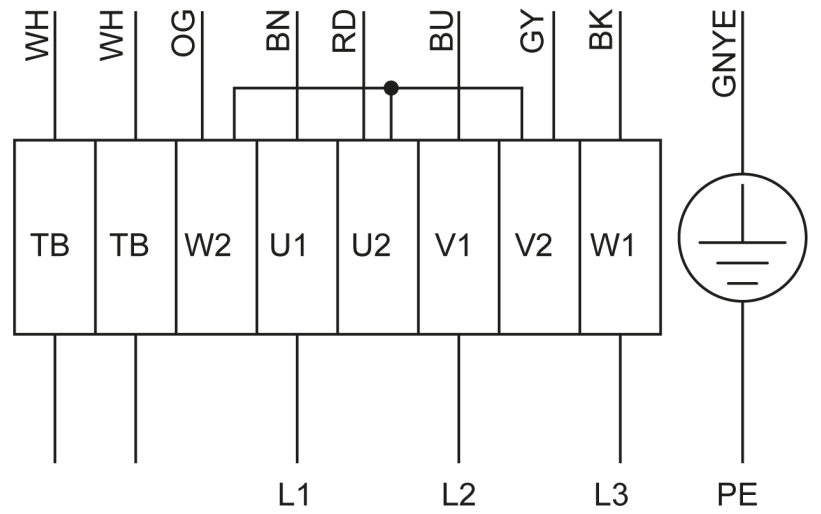

)LJ :LULQJ GLDJUDP RI WKH IDQ < FRQQH

4.6 Initial Setup

Setting Up the Air Equalizer

You can use the setup tables for the initial setup.

You can adapt the setup when the Air Equalizer does not operate as desired. It is recommended to adapt the Air Equalizer only in V P D steps. Continue to monitor the Air Equalizer during the full adaptation process.

Air Equalizer Setup for Houses 7

> P @

7DE 6HWXS WDE7OH IR@ KR XVHV

& R Q W U R O V		Reading (0-50 Hz)	J \$ F W X D W R U		Actual Opening		Total airflow = outside air intake + recycled volume of air		
Q W D N H F) F R Q \	F control	(T X D O S U F	6 W D W L F S U H V *	Equal pressure	Static pressure	Total airflow	Outside air intake	Recycled volume of air
		20 Hz	9	9	0%	0%	40%	0%	40%
		20 Hz	9	9	35%	25%	40%	9%	31%
		23 Hz	9	9	50%	40%	50%	19%	31%
		25 Hz	9	9	60%	50%	56%	30%	26%
		27 Hz	9	9	70%	60%	57%	40%	17%
		30 Hz	9	9	75%	65%	65%	51%	14%
		32 Hz	9	9	80%	70%	65%	59%	6%
		35 Hz	9	9	100%	90%	75%	70%	5%
		40 Hz	9	9	100%	100%	85%	80%	5%
		45 Hz	9	9	100%	100%	90%	90%	0%
		50 Hz	9	9	100%	100%	100%	100%	0%

0 D N H W K H V H V H W W L Q J V L Q \ R X U F O L P D W H F R Q

Air Equalizer Setup for Houses >

> P @

7DE 6HWXS WDEOH IRU KR XVHV ! > P @

& R Q W U R O V		Reading (0-50 Hz)	J S F W X D W R U		Actual Opening		Total airflow = outside air intake + recycled volume of air		
, Q W D N H F) F R Q \	F control	(T X D O S U F	6 W D W L F S U H V	Equal pressure	Static pressure ^ 3	Total airflow	Outside air intake	Recycled volume of air
		25 Hz	9	9	0%	0%	30%	0%	30%
		25 Hz	9	9	30%	20%	30%	9%	21%
		28 Hz	9	9	45%	35%	39%	19%	20%
		30 Hz	9	9	55%	45%	45%	30%	15%
		30 Hz	9	9	65%	55%	54%	40%	14%
		33 Hz	9	9	70%	60%	55%	51%	4%
		33 Hz	9	9	80%	70%	68%	59%	9%
		35 Hz	9	9	100%	90%	75%	70%	5%
		40 Hz	9	9	100%	100%	85%	80%	5%
		45 Hz	9	9	100%	100%	90%	90%	0%
		50 Hz	9	9	100%	100%	100%	100%	0%

0 D N H W K H V H V H W W L Q J V L Q \ R X U F O L P D W H

5 Maintenance



NOTICE!

- Let the fan operate to dry the Air Equalizer. This prevents corrosion of the motor after it is cleaned with water.
- When you use a high-pressure cleaner, do not spray the water directly on the fan and the actuator.

- ” Clean the Air Equalizer at least after each cycle with high-pressure air.
- ” Clean the propeller blades regularly to prevent imbalance in the system. Imbalance will cause excessive wear.
- ” Clean the bird protection from debris and other obstacles regularly to prevent disturbances of the air flow.
- ” Clean the shell with a high-pressure cleaner.
- ” When you use a cleaning solution, make sure that its temperature is not more than $> 60^{\circ}\text{C}$ when it gets out of the spray lance.
- ” The pH value of cleaning products must be between 4 and 12 to prevent damage to the Air Equalizer.
- ” It is recommended to spray below an angle of 45° .

Appendix

A Product Information

Air Equalizer

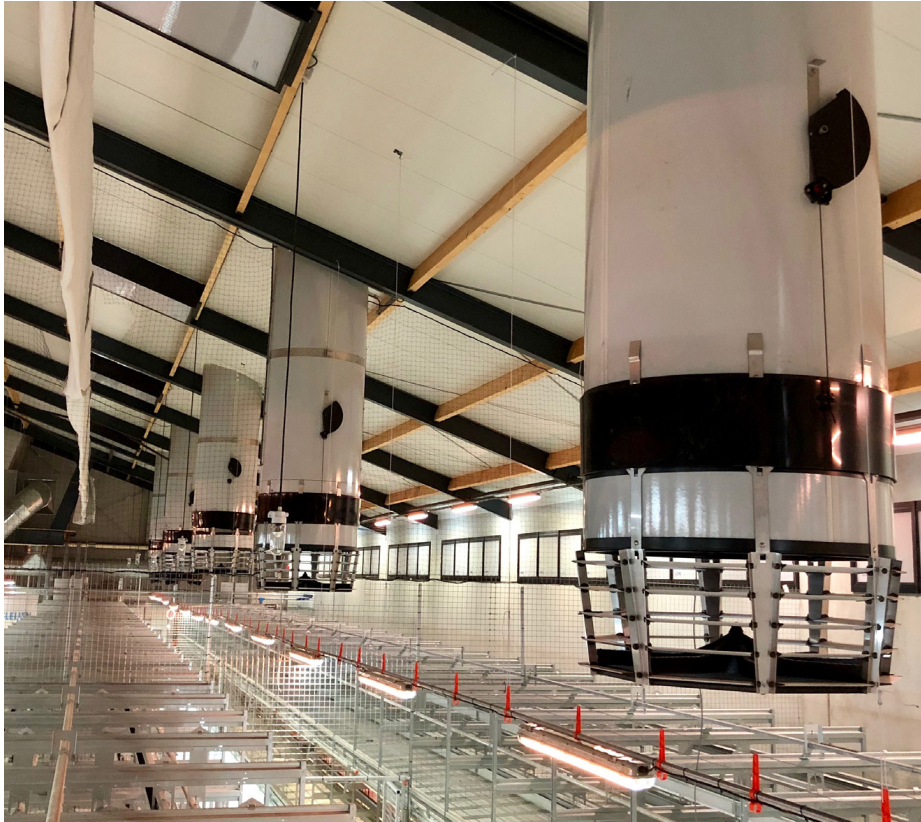

Fresh air inlet chimney

Adjustable air flow

Polyester coating

30 mm PU

By-pass

Easy controlled

Rigid

19.500 m³/h

AIR EQUALIZER

The **Air Equalizer** is a fresh air inlet chimney with the option to adjust the incoming air flow with adjustable spoilers/vanes.

The **Air Equalizer** is provided with a by-pass to mix warm barn air with the cold fresh air. The Equalizer does not change in height when using the by-pass. The by-pass can be regulated with an up and down moving ring. The incoming air can be managed with a damper. A computer controlled actuator operates the by-pass and the damper simultaneously.



Spoilers/vanes

There are 8 horizontal air directions per Equalizer. The air flow can be adjusted vertically separately for each zone or even completely blocked.

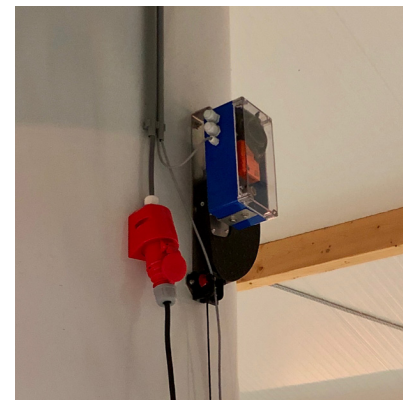

Actuator

The damper and the by-pass are controlled by a 0-10 volt Belimo actuator. When the damper closes, the by-pass opens and vice versa.

Technical information

Air flow data	
Type	Air Equalizer
0 Pa - m ³ /h	19.500
Diameter - mm (X)	920
Surface - cm ²	2200
Width - mm (X)	1000
Height - mm (Z)	1600
Depth - mm (Y)	1000

Insulation

The Air Equalizer is made of 30 mm foamed PU with a polyester shell. Insulation of the duct is necessary to prevent condensation on the outside of the duct.

The shell is hard and smooth and is easy to clean with high pressure.

Heat conductivity = 0,022 W/mK

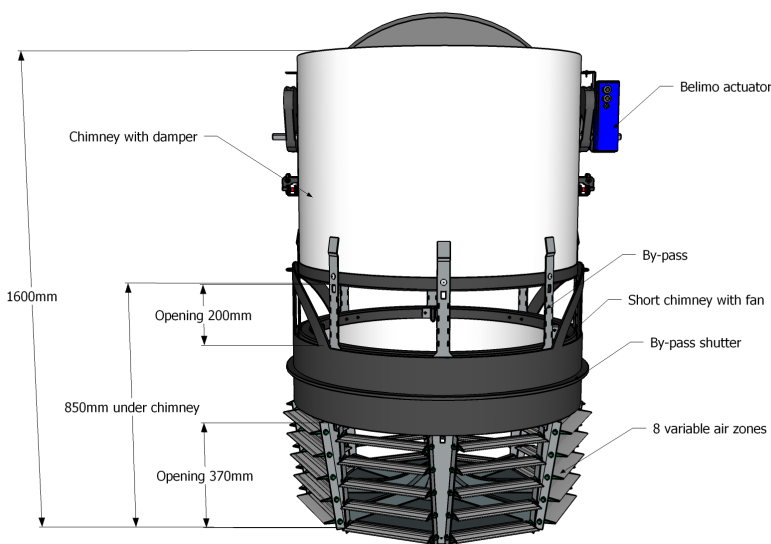

Dimensions

The product is 1.6 m high consisting of 750 mm tube with damper and the Air Equalizer unit of 850 mm high.

The Air Equalizer is supplied fully assembled.

Optional products:

- Rain hood
- Universal roof plate or corrugated plate
- Extension of the tube per meter
- Anchoring set

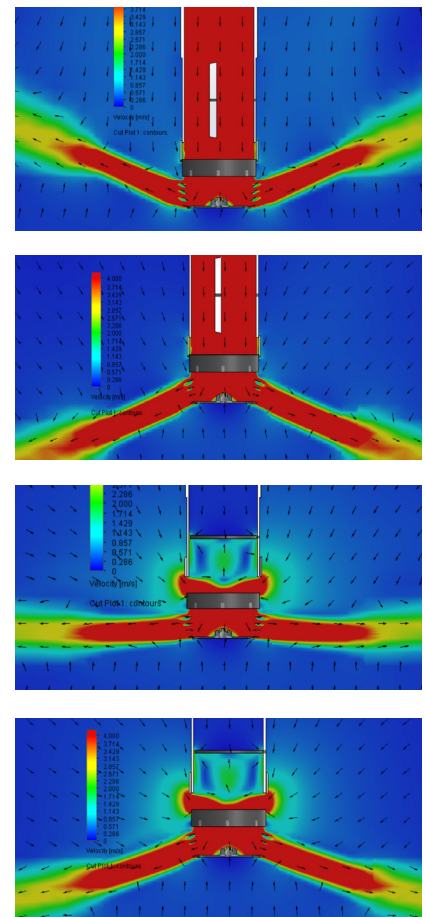

Flow

Air flow with different spoiler positions and by-pass openings

